



# FOTEK

**DEW POINT &  
HUMIDITY &  
TEMPERATURE**

**METER**



**ServoTech**  
伺服科技

伺服科技有限公司

<http://www.servo.com.cn>

香港葵涌製水道79號亞洲貿易中心1822室

Tel: (852)24841882 Fax: (852)24227107

- ◆ TRI METER ALL IN ONE
- ◆ LOWEST DEW POINT : -69°C
- ◆ DEW POINT TRANSMITTER  
(4 ~ 20 mA) OPTIONED
- ◆ HIGH ACCURACY : ±(0.1% OF FS)



陽明電機股份有限公司

◆DEW POINT & HUMIDITY & TEMPERATURE METER ALL IN ONE

"露點計 & 濕度計 & 溫度計"三合一

◆DEW POINT & TEMPERATURE SETTABLE

露點 & 溫度 可設定

◆LOWEST DEW POINT DISPLAY : - 69 °C

最低露點顯示 : - 69 °C

◆TO DISPLAY DP/TEMP OR HUM/TEMP SELECTABLE

可選擇顯示"露點 / 溫度" 或 "濕度 / 溫度"



## ■ SPECIFICATION / 規格

MODEL 型號	DPM-1	DPM-2	DPM-1-S	DPM-2-S
OUTLINE 外形	48 x 96	96 x 48	48 x 96	96x48
POWER SUPPLY 工作電壓	90~265 VAC, 50/60 Hz / 5 VA MAX.			
SENSOR 1 測溫體	K, J OR PT TYPE			
SENSOR 2 相對濕度感測器	RELATIVE HUMIDITY SENSOR <0.800VDC ~3.800VDC>			
TEMP OUTPUT 溫度控制輸出	RELAY 1c <5A/250VAC>			
DP/RH OUTPUT 露點/濕度控制輸出	RELAY 1a <5A/250VAC>			
CONTROL METHOD 控制方式	ON / OFF			
DP/RH TRANSMITTER 露點濕度再傳送	NON		4 ~ 20 mA	
RANGE OF HUMIDITY 濕度顯示範圍	0.0% ~ 99.9%			
RANGE OF DEW POINT 露點顯示範圍	- 69°C ~ 20.0°C			
RANGE OF TEMPERATURE 溫度顯示範圍	0°C ~ 999°C			
ACCURACY OF DISPLAY 顯示精度	± ( 0.1 % OF F.S. + 1 DIGIT)			
SETTING RANGE 設定範圍	±99			
TEMPERATURE SHIFT 溫度修正	±9.99			
HUMIDITY SHIFT 濕度修正	±9.99			
RESPONSE TIME 反應時間	1 SEC			
MEMORY METHOD 記憶方式	EEPROM			
INSULATION RESISTANCE 絕緣強度	OVER 50MΩ			
DIELECTRIC STRENGTH 耐壓強度	OVER 2.5 KV/ 1 MINUTE			
OPERATING CIRCUMSTANCE 使用環境	20°C ~ 75°C ; 35%~85% RH			
EMC STANDARD	ESD : 8 KV AIR CHARGE < LEVEL 3>/EN-61000-4-2			
	BURST TEST : 2 KV / EN61000-4-4			

## SETTING OF PARAMETER / 參數設定





## SETTING OF TRANSMITTER / 傳送設定

MONITOR SELECTING	SYMBOLS	REMARKS
STATUS OF NORMAL 監視狀態	00.0d 00c	1>d : DEW POINT ; c or F : TEMPERATURE d : 露點                      c or F : 溫度
PRESS "SET" ↓ KEY 3 SEC		
SETTING OF LOCK 鎖定設定	Lcℓ 0	1> 0 : ALL SETTING ARE UNLOCK 1 : SV SETTABLE 2 : SV SETTABLE 3 : ALL LOCK
PRESS "SET" ↓ KEY		
HI LIMIT OF TRANSMITTER 傳送上限設定	SLH 90	1> THE SLH IS CONVERTED TO "20.0" mA "SLH"轉成"20.0mA"
PRESS "SET" ↓ KEY		
LO LIMIT OF TRANSMITTER 傳送下限設定	SLL 0	1> THE "SLL" IS CONVERTED TO "4.0" mA "SLL"轉成"4.0mA"
PRESS "SET" ↓ KEY		
LO LIMIT OF DP 露點下限值設定	dPL -5l	

## CONNECTION DIAGRAM / 接線圖

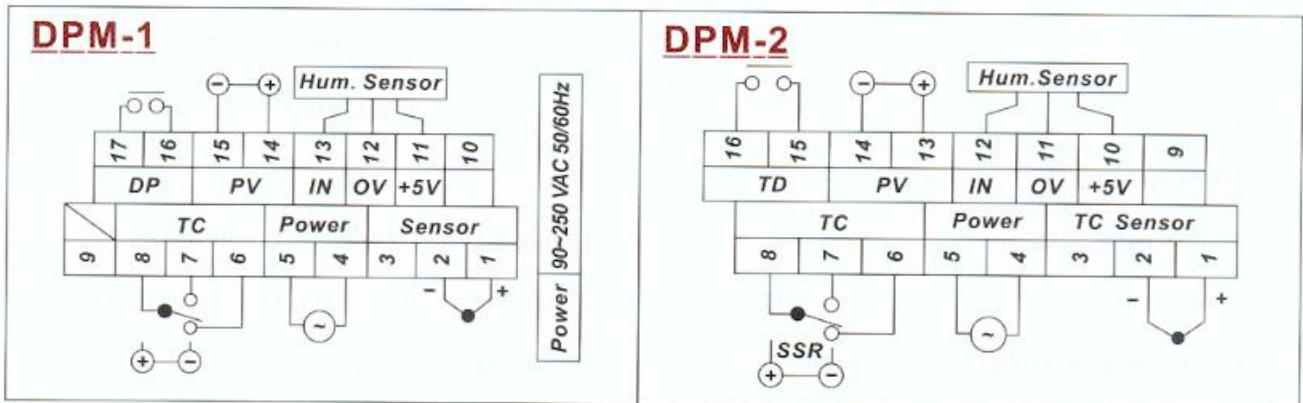

## OUTLINE DIMENSION 外形尺寸圖

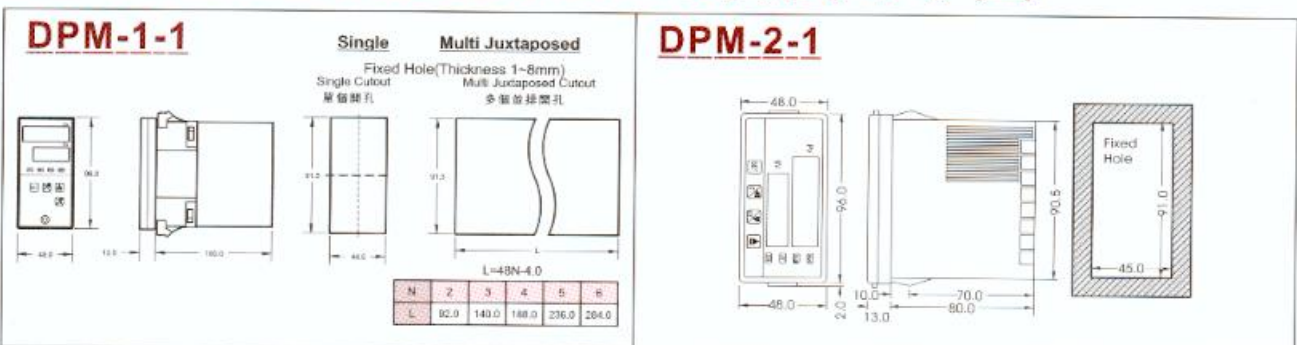

◆LINEAR VOLTAGE OUTPUT vs %RH

相對濕度對應電壓線性輸出

◆HIGH ACCURACY : ±2.0% RH

高精度 : ±2.0% RH

◆FAST RESPONSE TIME : 15 SEC

快速應答 : 15 SEC

◆STABLE & LOW DRIFT PERFORMANCE

高穩定性 & 低飄移特性

◆CHEMICALLY RESISTANCE

抗化學腐蝕



## SPECIFICATION

MODEL	型號	HS-1	HS-2
OPERATING VOLTAGE	工作電壓	4.0V DC~ 5.5VDC	
CURRENT CONSUMPTION	耗電流	200 $\mu$ A TYPICAL	
OPERATING HUMIDITY RANGE	濕度範圍	0 ~ 100% RH, NON-CONDENSING	
RH ACCURACY	RH 精度	$\pm$ 2.0% RH	
RH LINEARITY	線性度	$\pm$ 0.5% RH	
RH HYSTERESIS	應差	$\pm$ 1.2% RH OF FS	
RH REPEATABILITY	重復性	$\pm$ 0.5%	
RH RESPONSE TIME	響應時間	15 SEC IN SLOWLY MOVING AIR @ 25°C	
RH STABILITY	穩定性	$\pm$ 1.0% RH TYPICAL AT 50% RH IN 5 YEARS	
CONNECTION METHOD	出線方式	M12 CONNECTOR	
OPERATING TEMPERATURE	工作溫度	- 40°C ~ 85°C	
COMMENT	注意事項	LIGHT SENSITIVE, SHIELDED FROM BRIGHT LIGHT	

## CONNECTION DIAGRAM

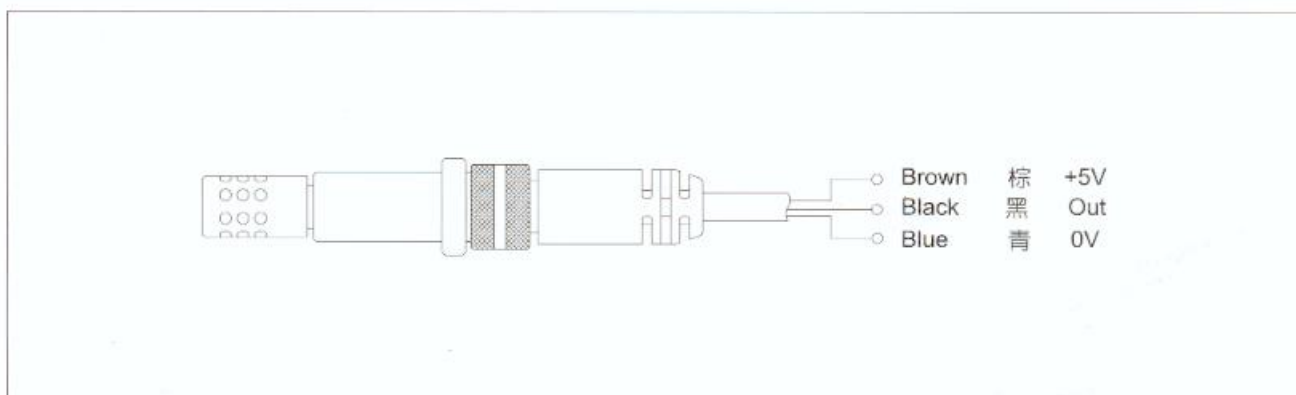

## OUTLINE DIMENSION

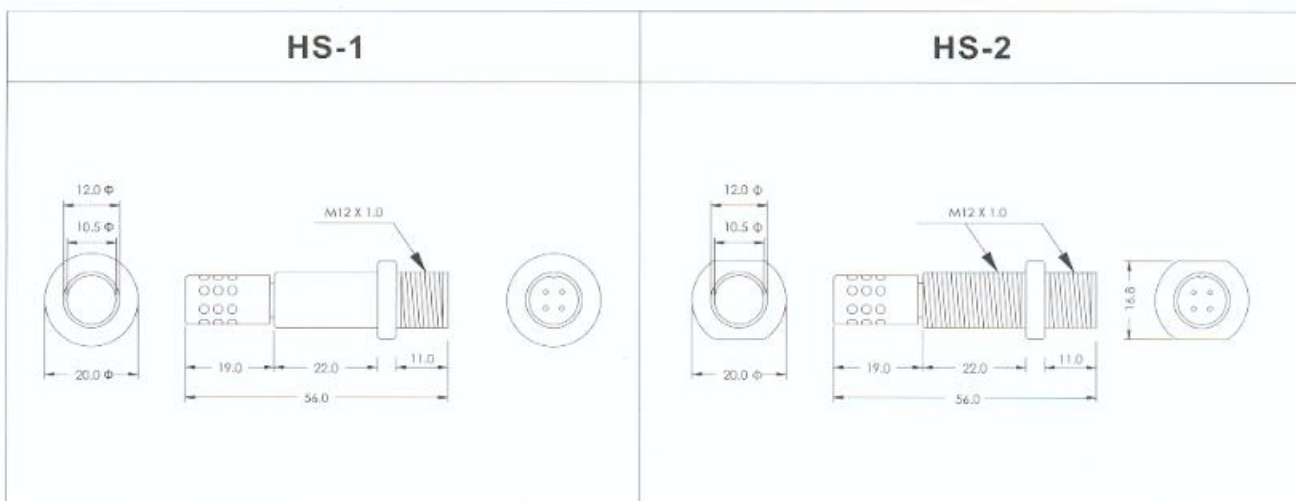





**TO MANUFACTURE THE WORLD STANDARD CONTROLS  
BY MASS PRODUCING & STANDARDIZING  
TO OFFER THE EXCELLENT QUALITY ASSURANCE  
BY ADVANCED TECHNOLOGY &  
STRICT TOTAL QUALITY CONTROL**

量產化、標準化；製造世界標準的電控器材  
先進技術、嚴格品管；提供最佳品質保證