

- High Compact Structure
- 13.5 (W) X 25.0 (H) X 30.0 (L)
- High Protection Class
- IP-67
- Long Sensing Distance
- Reflex Type : 30cm , 60cm
 - Mirror Reflex Type : 2m
 - Thru Beam Type : 6m

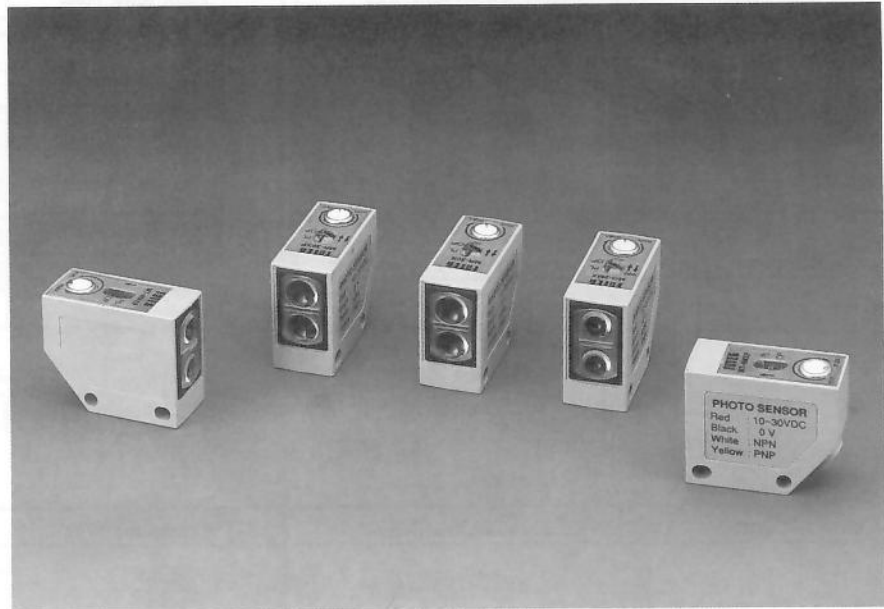

General Specification

Specification	Data
Operating Voltage	10 ~ 30 VDC ; Ripple < 20% of Peak to Peak
Output Method	NPN & PNP Two Output
Output Status	NO < Normal Open > , NC Type Available Also
Output Current	150mA max.
Leakage Current	0.8mA max.
Residual Voltage	0.6V max.
Protection Circuit	Short Circuit & Polarity Reversed Protection
Response Time	2ms Max.
Sensitivity Adjuster	270° Trimmer
Emitter	Infrared LED
Illumination	Sunlight < 10,000 Lux. ; Lamplight < 5,000 Lux.
Hysteresis	10% of Sensing Distance Max.
Housing Material	Case : PBT ; Lens : PC
Operating Temp./Hum.	-20°C ~ +60°C ; 35% ~ 85% RH
Connection Method	Lead Wire Type : 4 Cores / 5.0 φ X 2m Plug Type : 4 Pins
Model of NC Type	Reflex Type : MR-30XB , MR-30XPB , MR-60XB , MR-60XPB PR-30XB , PR-30XPB , PR-60XB , PR-MXPB Mirror Reflex Type : MG-2MXB , MG-2MXPB , PG-2MXB , PG-2MXPB Thru Beam Type : MT-6MXB , MT-6MXPB , PT-6MXB , PT-6MXPB
Remarks	Water Proof By Expose Filled for IP-67

Reflex Type

Type	Lead Wire Type				Plug Type			
Model	MR-30X	MR-30XP	MR-60X	MR-60XP	PR-30X	PR-30XP	PR-60X	PR-60XP
Protection Class	IP-65	IP-67	IP-65	IP-67	IP-65	IP-67	IP-65	IP-67
Sensing Distance	30cm		60cm		30cm		60cm	
Operating Voltage	10~30 VDC ; Ripple < 20% Peak to Peak							
Current Consumption	30mA max.							
Output Method	NPN & PNP Two Way Output							
Output Status	NO < Normal Open >							
Output Current	150mA max.							
Emitter	Infrared LED							
Protection Circuit	Short Circuit & Polarity Reversed Protection							
Weight < Appr. >	78g	84g	78g	84g	12g	18g	12g	18g

Mirror Reflex Type

Type	Lead Wire Type		Plug Type	
Model	MG-2MX	MG-2MXP	PG-2MX	PG-2MXP
Protection Class	IP-65	IP-67	IP-65	IP-67
Sensing Distance	2m			
Operating Voltage	10~30 VDC ; Ripple < 20% Peak to Peak			
Current Consumption	30mA max.			
Output Method	NPN & PNP Two Way Output			
Output Status	NO < Normal Open >			
Output Current	150mA max.			
Emitter	Infrared LED			
Protection Circuit	Short Circuit & Polarity Reversed Protection			
Weight < Appr. >	78g	84g	12g	18g

Thru Beam Type

Type	Lead Wire Type		Plug Type	
Model	MT-6MX	MT-6MXP	PT-6MX	PT-6MXP
Protection Class	IP-65	IP-67	IP-65	IP-67
Sensing Distance	6m		6m	
Operating Voltage	10~30 VDC ; Ripple < 20% Peak to Peak			
Current Consumption	Emitter < 20mA , Receiver < 25mA			
Output Method	NPN & PNP Two Way Output			
Output Status	NO < Normal Open >			
Output Current	150mA max.			
Emitter	Infrared LED			
Protection Circuit	Short Circuit & Polarity Reversed Protection			
Weight < Appr. >	180g	162g	20g	32g

MS Series

MINI & WATER-PROOF PHOTO SENSOR

Output Circuit & Connection Diagram

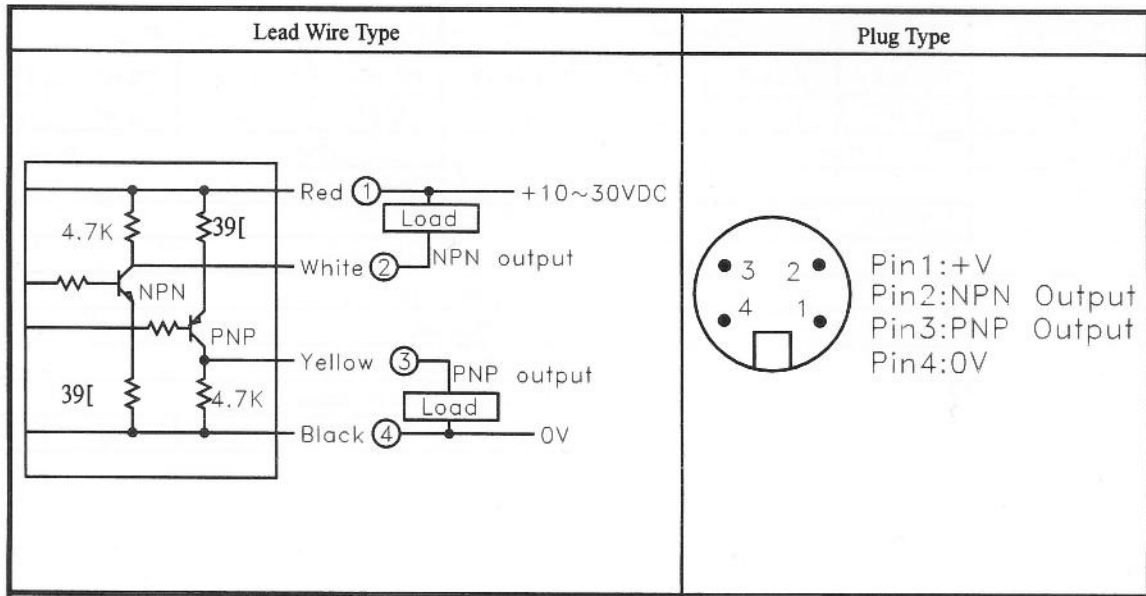

Dimension

